

SOLDER POT
POT-100C / 103C
POT-200C / 203C



WARNING

Read this Owner's Operation Manual before using your solder pot. Failure to follow the safety precautions and instructions in this manual could result in serious injury and property damage.

Thank you for buying a goot Solder Pot. Your new solder pot has been engineered and manufactured to the goot high standard for dependability, ease of operation, and operator safety. Please follow this operation manual for your continued safety and operational comfort.

KEEP THIS MANUAL FOR FUTURE REFERENCE

SAFETY MARK DEFINITIONS

The following marks of WARNING and CAUTION are defined below.
Please make sure you fully understand the contents to ensure proper use and protection of operator and others from injury and damage.



WARNING

Failure to obey a safety warning could result in serious injury or death to yourself or to others. Always follow the safety precautions to reduce the risk of electric shock, fire or personal injury.



CAUTION

Failure to obey a safety caution could result in a minor or moderate injury to yourself or to others. Always follow the safety precautions to reduce the risk of electric shock, fire or personal injury.

NOTE

A note or word of advice. Always follow as the note tells you.

1. TABLE OF CONTENTS

SAFETY MARK DEFINITIONS2

1. TABLE OF CONTENTS3

2. SAFETY INFORMATION.....4

3. SPECIFICATIONS5

 3-1. FEATURES5

 3-2. SPECIFICATIONS5

4. PACKAGE CONTENTS.....6

5. HOW TO SET UP7

 5-1. SET UP.....7

 5-2. FUNCTIONS OF CONTROL PANEL.....8

 5-3. HOW TO SET THE VALUE9

6. MAINTENANCE10

7. IN THE EVENT OF A FAILURE.....10

8. REPLACEMENT PARTS.....11

 8-1. REPLACEMENT PROCEDURES.....11

 8-2. REPLACEMENT / OPTION PARTS13

2. SAFETY INFORMATION

To assure safe operation, read and always follow the rules below.



WARNING

Do not attempt to operate the unit before you have read thoroughly and understood completely all instructions, safety rules, etc. contained in this manual.



WARNING

Make sure that the machine must be grounded at all times to prevent electrical shocks and static electricity. If it is not properly grounded, electrical shocks may occur.

1. KNOW YOUR SOLDER POT

Read the operation manual carefully. Safe operation of the unit requires that you read and understand this operation manual and all labels affixed to the unit. You should be alert to the possible dangers, application and usage restrictions on this unit.

2. DO NOT USE IN DANGEROUS ENVIRONMENTS

Do not use it in damp, humid or wet locations, or expose it to rain. Do not use outside. Never use it in a potentially explosive area. Ignition may occur through the heater. Keep the work area well lit.

3. KEEP CHILDREN AND BYSTANDERS AWAY FROM THE UNIT

Do not let bystanders touch the unit. All children and bystanders should be kept a safe distance from the work area.

The solder pot is not to be used by children or persons with reduced physical, sensory or mental capabilities, or lack of experience and knowledge, unless they have given supervision or instruction. Children being supervised not to play with the solder pot.

4. USE CORRECTLY

Do not use this for any purpose other than dipping into solder. Do not touch any side of the solder pot when it is hot except the temperature control panel and the main power switch.

5. WEAR PROPER APPAREL AND SAFETY GLASSES

Do not wear loose clothing such as a necktie. Tie up long hair. Clothing or hair can be burnt by coming into the solder in the pot or surrounding heated parts.

6. CONNECT TO A CORRECT POWER SUPPLY

Do not use with any power voltage other than the indicated voltage.

7. DO NOT BEND THE POWER CORD

Keep the power cord away from heat, oil, and sharp edges. Requires periodic inspections.

If the power cable is damaged then the solder pot should be returned to the distributor or authorized service center for replacement.

8. BE CAREFUL ABOUT THE EROSION OF THE BATH

The pot will become corroded by the solder over long-term operation. This corrosion may cause a hole, and melted solder leakage. Thus, the bath needs to be replaced before solder corrodes bath surfaces.

SOLDER	Sn-Pb Eutectic solder		Sn-Ag-Cu Lead-free solder	
Operating Temperature	250°C	350°C	270°C	450°C
POT-100C/200C	3 years	1 year	Not available	
POT-103C/203C	5 years more		5 years	3 years

This table compares the bath lives of goot POT-100C/200C and POT-103C/203C. It is only a guide. When using more chlor-flux, erosion is faster. And note that the chlorine will rust the bath surface.

3. SPECIFICATIONS

3-1. Features

- Dual digital display shows set temperature and measured temperature visually.
- PID temperature control minimizes deviation between the actual solder temperature and the set temperature.
- Warning lamp to detect any deviance from set temperature range.
- Lead-free applicable (POT-103C/203C)

3-2. Specifications

MODEL	POT-100C	POT-103C	POT-200C	POT-203C
Voltage	110V, 120V 220V, 230V, 240V, AC 50/60Hz	110-120V 220 - 240V AC 50/60Hz	110V, 120V 220V, 230V, 240V, AC 50/60Hz	110-120V 220 - 240V AC 50/60Hz
Power Consumption	440W	900W	650W	1400W
Max. Temperature	350°C	450°C	400°C	450°C
Control System	PID Control			
Dimensions	220×380×124(H)mm		220×450×124(H)mm	
Bath Dimensions	91×135×60(D)mm	82×110×53(D)mm	130×180×60(D)mm	108×170×53(D)mm
Weight	approx. 4.5kg	approx. 8kg	approx. 6kg	approx. 11kg
Max. Solder Volume	approx. 5.5kg	approx. 3.5kg	approx. 9.5kg	approx. 7kg
Bath Material	SUS316	Cast Iron	SUS316	Cast Iron
Temp. Accuracy	±[(1.25% of display temperature)+1°C]			
Power Cord	3-prong cord 1.3m w/ground plug	3-prong cord 1.5m w/o plug	3-prong cord 1.3m w/ground plug	3-prong cord 1.5m w/o plug

NOTE

The PID controller is preset to the optimum temperature 270°C for dipping PCBs.

The ALM (alarm) lamp will light up when the temperature is 5°C higher or lower than the set temperature.

For further information about the temperature controller installed in the solder pot, please refer to the operation manual RB series(RKC INSTRUMENT INC.) included in the box.

4. PACKAGE CONTENTS

Make sure that all the items listed below are included. And store the packaging until making sure that the pot functions properly.

- Main unit



- Instruction manuals (for POT, RB series quick operation / Parameter)

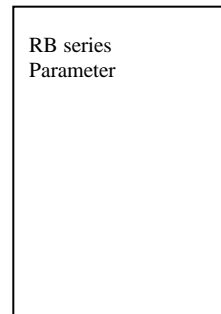
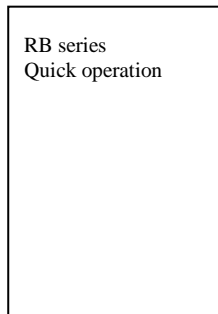
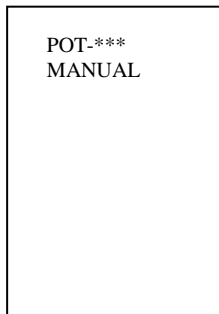

- Tray

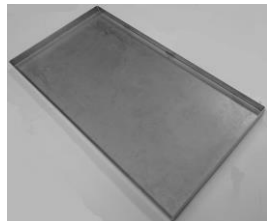

- Slag holder

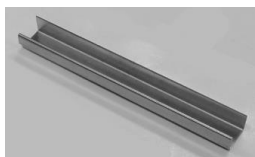

- Slag remover

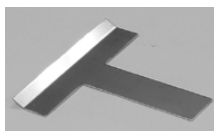

- Solder bath cover

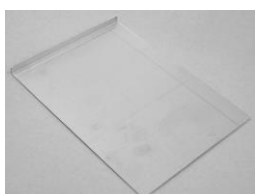

5. HOW TO SET UP



WARNING

Be sure to install the solder pot on a firm metal bench. The solder pot becomes heavy with the solder. The solder pot and surroundings also become very hot. Handle with care to avoid fire or burning yourself.

5-1. Set up

1. Position the tray provided under the solder pot.
2. Hook the slag holder to the side of the top plate.

tray

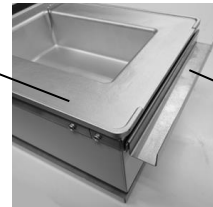

slag holder

3. Check that the power switch is OFF (O side), and connect the power cord.
*POT-100C/200C: Plug the power cord into an outlet.
*POT-103C/203C: Connect the power cord to the switchboard.
(If using power plug, be careful about its power rating.)

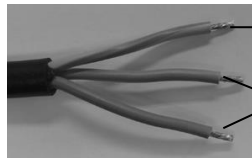

yellow-and green stripes: earth

blue or brown (single wire)

4. Put the appropriate volume of solder into the bath. (See Max. solder volume in the specifications)
The proper amount of melted solder is about 1cm below the rim of the pot.
5. Turn the main power switch ON (to I side).
6. Set the temperature, following the setting procedures of the control panel explained in 5-3. The factory default temperature is 270°C.
7. After setting, the control output lamp (OUT1) of the control panel will light up, and temperature control will start. The solder melts in about 40-50 minutes. Remove the oxidized slag on the solder surface with the slag remover, and start dipping.
8. Be sure to turn OFF the main power switch when solder pot is not in use, and when stepping away from the unit.



WARNING

Use the solder pot cover for the **POT-200C** included with the solder pot.

Before turning the solder pot ON each day, be sure that it is properly on the top and do not remove until the solder melts fully.

The solder may splatter from the solder pot while it is melting.

Be careful when removing the plate, as it is hot and will cause burns.

Failure to cover the solder pot could result in serious injury, a fire or damage.

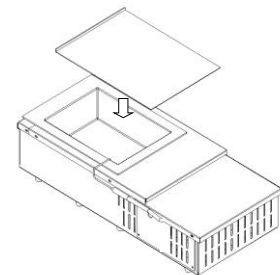

5-2. Functions of Control Panel

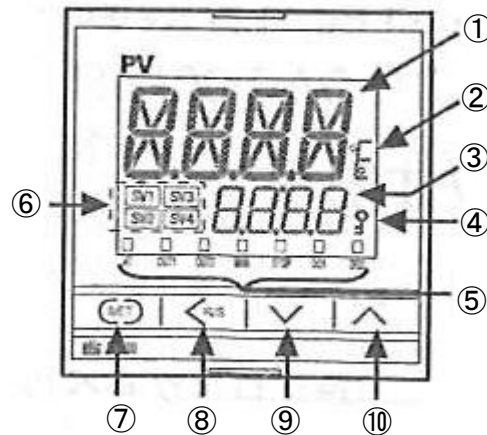

1. PRESENT VALUE (PV) DISPLAY

Displays the actual measured value (PV) and each parameter.

2. INDICATION OF MEASUREMENT UNITS

Displays the unit of temperature(°C or °F), or manipulated value(MV) or each parameter.

3. SETTING VALUE (SV) DISPLAY

Displays the manipulated value(MV) or each parameter.

4. KEY LOCK LAMP

Lights up when the unit is in Key Lock mode.

5. AT LAMP

Flashes during the Auto-Tuning mode (AT).

OUTPUT LAMP OUT1: Lights up when OUT1 is ON.

OUTPUT LAMP OUT2: Lights up when OUT2 is ON.

MAN LAMP: Lights up when manual (MAN) mode.

STOP LAMP: Lights up when in control stopped.

DO OUTPUT: LAMP Lights up when each event output (DO1-DO4) is ON.

6. STEP VALUE LAMP

Lights up the lamp which meets the setting value (SV1-SV4) in use when using step SV function or timer function.

7. SET KEY

Use to call up the parameter or set the value.

8. SHIFT KEY

Use to shift the digits for setting change.

9. DOWN KEY

Use to decrease the setting value.

10. UP KEY

Use to increase the setting value.

5-3. How to set the value

Example: Inputting 400°C as the set value (SV) (PV value: 30°C).

[Enter the setting mode]

Press the **SET** key to enter the SV setting mode.

The lowest digit in the SV display will flash.

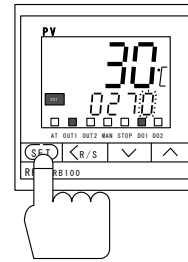

[Digit shifting]

Press the **<R/S** key and shift the flashing digit to the ten's digit.

Every pressing of the **<R/S** key will shift the flashing digit as shown right.

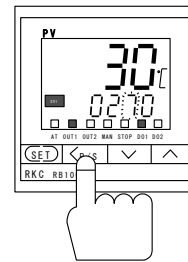

[Increase/decrease the value]

Press **Δ** key and display the number "0".

Δ key increases the value, and **∇** key decreases the value.

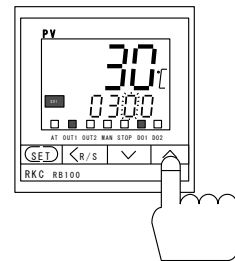

[Digit shifting]

Press the **<R/S** key and shift the flashing digit to the hundred's digit.

And press the **Δ** key to select the number "4".

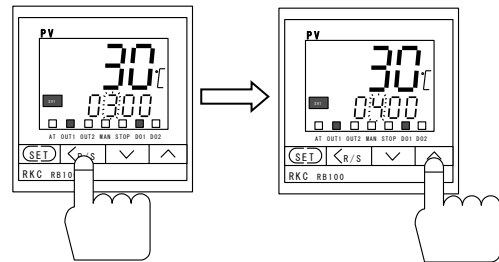

[Registering the set value]

After finishing the settings, press the **SET** key.

The display stops flashing the set value, and shows PV SV mode.

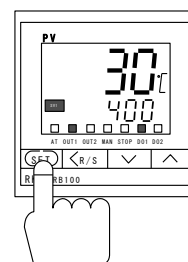

NOTE

The setting value cannot be set above the max operating temperature. See max operating temperature in the 3-2.specifications.

6. MAINTENANCE

- Make sure that the tip of the sensor is always in the melted solder. Always keep the melted solder volume at about 1cm below the rim of the pot.
- When using the solder pot for long periods, oxidized dross may accumulate around the walls of the solder bath. This can cause poor heat transmission from the heater, overheating and insufficient heating of the solder. Periodically scrape the walls of the solder bath with the spatula included with the unit to remove oxidized dross. And handle with care to avoid fire or burning yourself.

7. IN THE EVENT OF A FAILURE

Proceed with the following steps if you have any problems.

1. Check that the power cord is plugged in, and the circuit breaker is set to the ON position.
2. Check that the power cord is not damaged. If you notice any signs of damage, please contact your distributor.
3. Check that the fuse has not blown out. If the fuse has blown out, please replace it (POT-100C/200C/103C).
4. On POT-203C the main power switch has a built-in breaker function. If the main power switch does not turn ON, this situation may cause a leak current and/or short-circuit. Unplug the power cord and contact your distributor.

8. REPLACEMENT PARTS

8-1. Replacement procedures



WARNING

Turn off the main power switch and unplug the power cord before changing the solder bath, heater or sensor. Do not start replacing work until the unit has completely cooled down.

Heater Replacement

POT-100C/200C

1. Turn off the main power switch and unplug the power cord. Wait till the bath has completely cooled down.
2. Remove the sensor-fixing bracket. Take out the bath and sensor from the solder POT unit. Handle with special care not to damage the sensor.
3. Dismount the top plates A & B.
4. Take out the shield board.
5. Remove the nuts (2 locations) which fix the heater-lead wire. Be careful not to loosen the bottom nuts.
6. Remove the nuts which fix the ground wire.
7. Pull out the bath only.
8. Take out the heaters.
9. Reassemble with new heaters, reversing these steps.

POT-103C/203C

1. The same steps as the procedure of Heater Replacement POT-100C/200C 1-5.
2. Remove the screws which fix the ground wire.
3. Pull out the bath with the front heat insulation board.
4. Remove the screws which fix the fixing bracket. Take out the heaters A & B, and dismount the heat insulation board.
5. Remove the nuts (2 locations) and take out the heater lead wire.
6. Fix the heater lead wire to new heaters with the nuts (2 locations).
7. Reassemble with new heaters, reversing these steps.

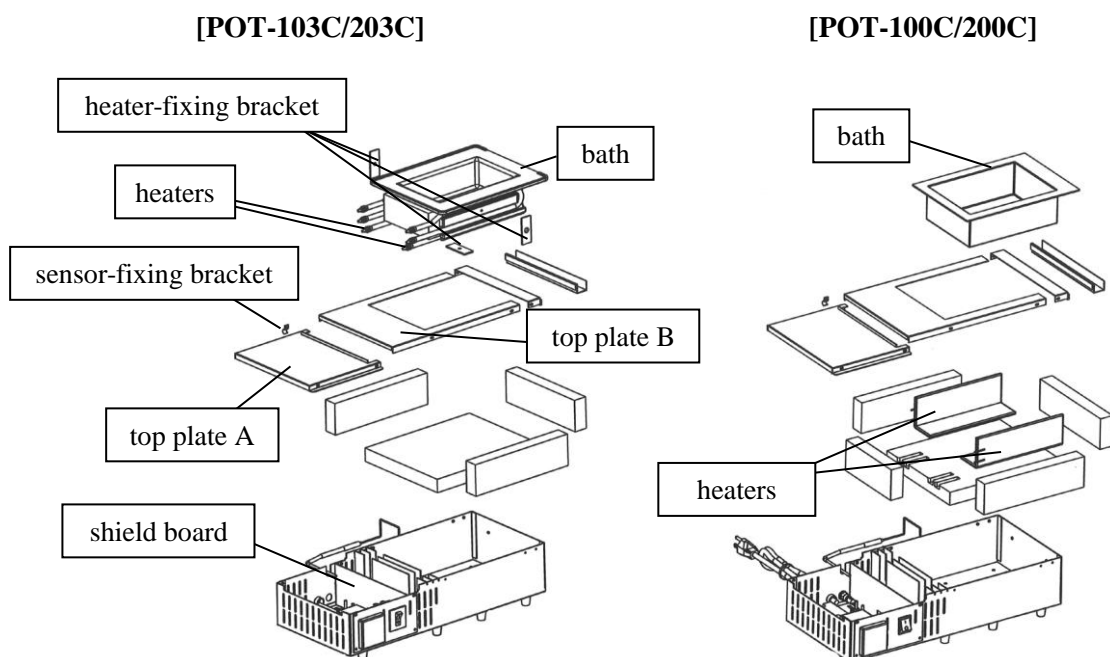

Bath Replacement

POT-100C/200C

1. The same steps as the procedure of Heater Replacement POT-100C/200C 1-2.
2. Pull out the bath.
3. Mount a new bath.

POT-103C/203C

1. The same steps as the procedure of Heater Replacement POT-103C/203C 1-4.
2. Remove the screws and take out the ground wire.
3. Fix the ground wire to a new bath with the screws.
4. Reassemble with new heaters, reversing these steps.

Sensor Replacement



WARNING

Sensor replacement must be done in melted solder. It is very dangerous. Contact your nearest distributor

8-2. Replacement / Option parts

POT-100C

NO.	ITEM
1	Heater [POT-100CH]
2	Bath [POT-100CP]
3	Fuse 250V 10A
4-6	Heat insulation board set (Only available as a set)
7	Tray for POT-100C/103C
8	Slag remover for POT-100C/103C/200C/203C
9	Slag holder for POT-100C/103C/200C/203C
10	PCB holder for dipping (Option) PCB-1

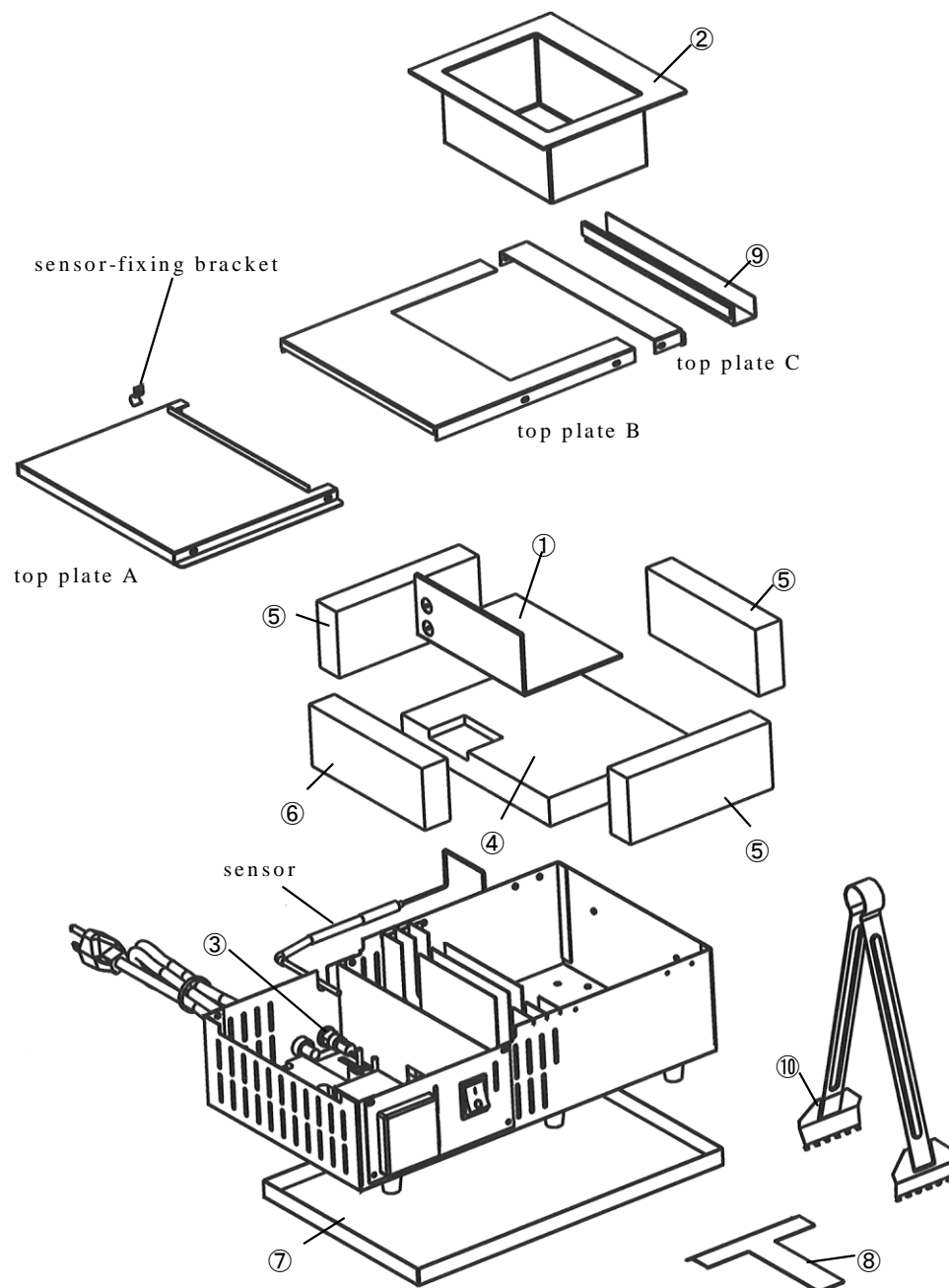

POT-103C

NO.	ITEM
1	Heater at bottom face [POT-103CHA]
2	Heater at side face [POT-103CHB]
3	Bath [POT-103CP]
4	Fuse 250V 10A
5-7	Heat insulation board set (Only available as a set)
8	Tray for POT-100C/103C
9	Slag remover for POT-100C/103C/200C/203C
10	Slag holder for POT-100C/103C/200C/203C
11	PCB holder for dipping (Option) PCB-1

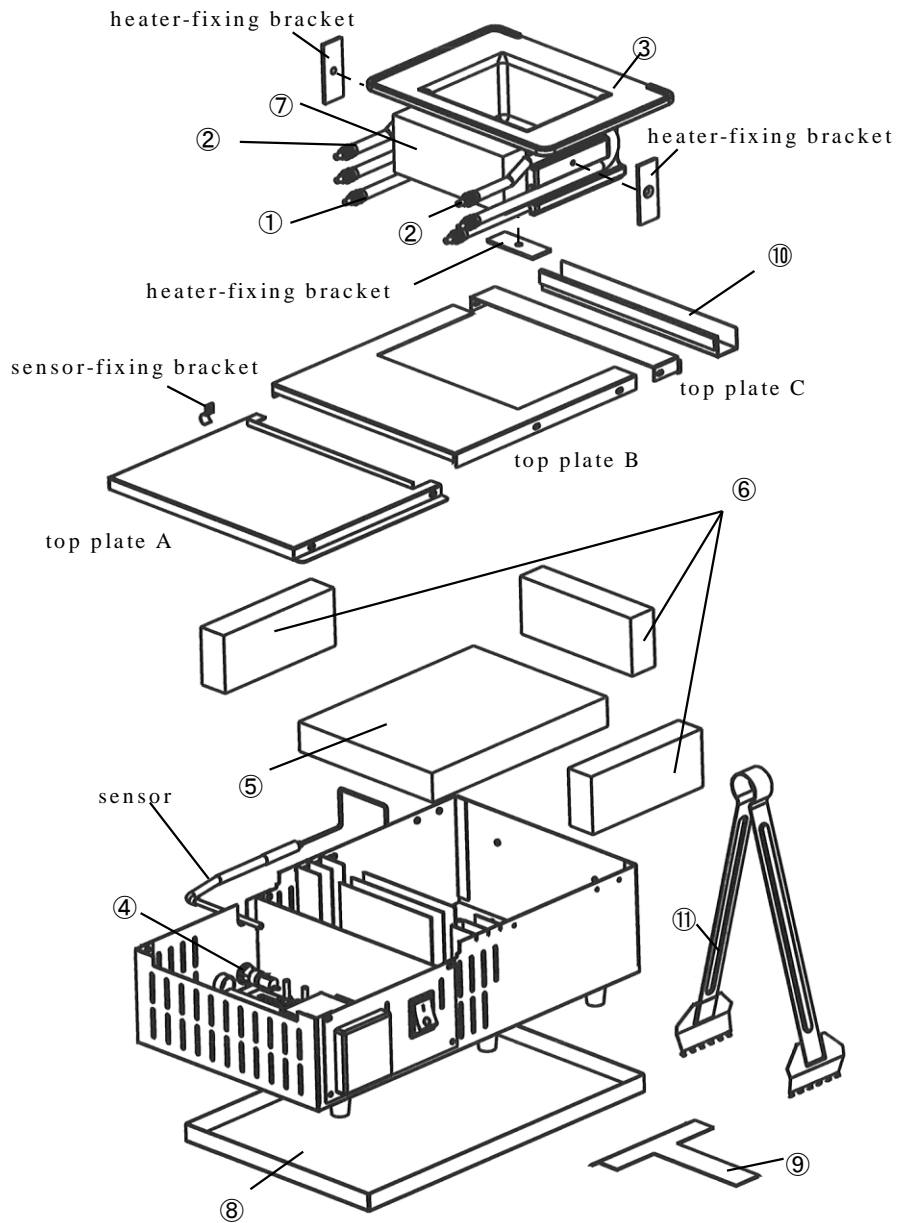

POT-200C

NO.	ITEM	
1	Heater at right side [POT-200CHR]	Heater set [POT-200CHS]
2	Heater at left side [POT-200CHL]	
3	Bath [POT-200CP]	
4	Fuse 250V 10A	
5-8	Heat insulation board set (Only available as a set)	
9	Tray for POT-200C/203C	
10	Slag remover for POT-100C/103C/200C/203C	
11	Slag holder for POT-100C/103C/200C/203C	
12	PCB holder for dipping (Option) PCB-1	
13	Solder pot cover POT-200C-TCV	

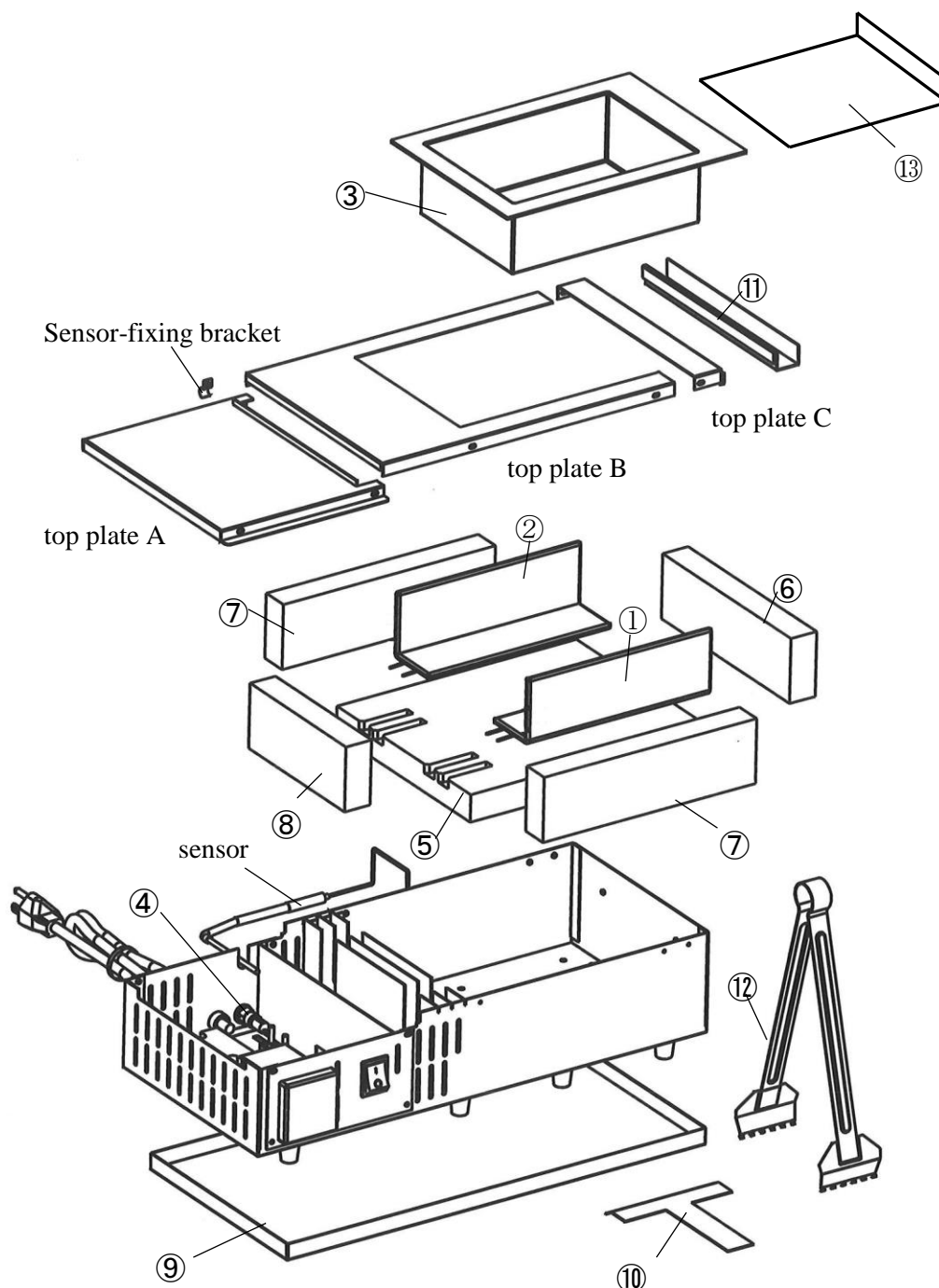

POT-203C

NO.	ITEM
1	Heater at bottom face [POT-203CHA]
2	Heater at side face [POT-203CHB]
3	Bath [POT-203CP]
4-7	Heat insulation board set (Only available as a set)
8	Tray for POT-200C/203C
9	Slag remover for POT-100C/103C/200C/203C
10	Slag holder for POT-100C/103C/200C/203C
11	PCB holder for dipping (Option) PCB-1

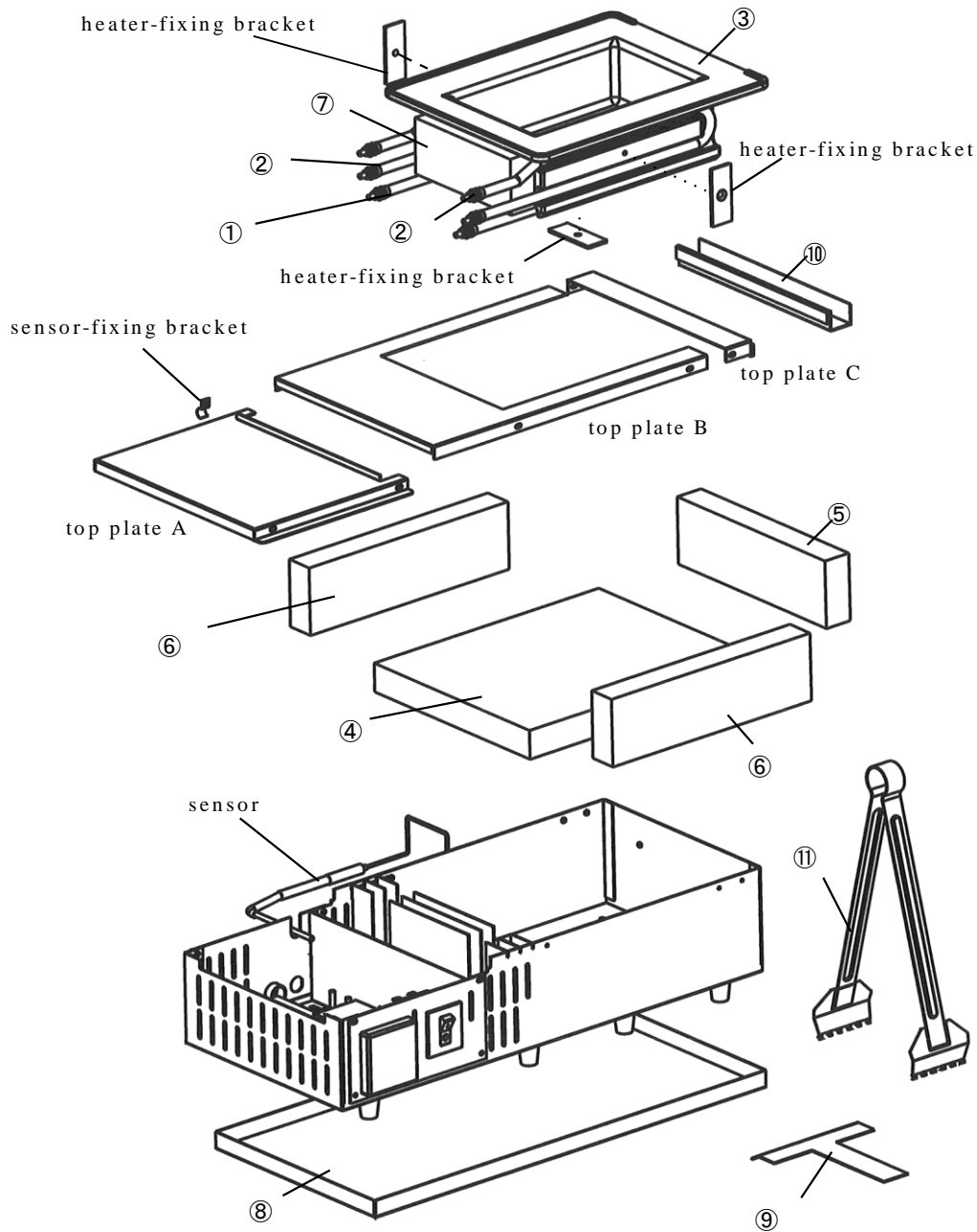

	SOLDERING EQUIPMENT AND ACCESSORIES TAIYO ELECTRIC IND.CO.,LTD.	Web site: www.goot.co.jp/e E-mail: info@goot.co.jp TEL: (81)84-951-1512
	Head Office 2-16-8 Yamate Fukuyama Hiroshima 720-0092 Japan	

"goot" is registered trade mark of TAIYO ELECTRIC IND.CO.,LTD.

Printed in Japan OCTOBER 2015 4330HP00